INTECH Micro 2300-D16



16 Channel Digital Input Station

Overview.

The Intech Micro 2300 series is a system of modular I/O Remote Stations, that add an even lower cost option to Intech's already extensive intelligent I/O Remote Station family, which connect automatically to the Intech MicroScan V5 logging plus SCADA software package.

The 2300 series I/O stations are made up of stand-alone Digital and Analogue—Input/Output stations. Communications between the computer running MicroScan V5 and the 2300 series stations is RS485 (1 pair cable) multi drop as standard, with an option for Ethernet TCP/IP.

A 32bit ARM CPU is used in the 2300 series stations to provide high speed data processing and fast communications turn around times. All 2300 series stations have been equipped with status LED's which are used to indicate the status of the Inputs or Outputs. This visual indication assists with fault finding and diagnostics.

All the I/O stations clip directly onto an industry standard DIN rail. All stations have a minimum isolation of 1000Vac rms between the field and logic.

Installation Guide.

When connecting to MicroScan V5 software.

2300-D16 Installation Guide Index.

Description, Ordering and Specifications.

Dimensions.	Page 2
Features.	Page 3
Description and Ordering Information.	Page 3
Factory Configurations.	Page 3
I/O Expansion.	Page 3
Specifications.	Page 4
Status Indicators.	Page 4

Station ID Tables.

Dip Switch Settings.	Page 5/6
----------------------	----------

Connections and Comms Wiring.

Power and RS485 Comms Wiring.	Page 6
Connection Example Diagrams.	Page 7
Computer to 2300 Series Comms Connections - 2400-IS:	Page 8
Computer to 2300 Series Comms Connections - 2100-IS:	Page 9
Computer to 2300 Series Comms Connections - 2300-NET:	Page 10

Wiring & Installation.

Mounting.	Page 11
Power Supply Wiring.	Page 11
RS485 Comms Signal Cabling.	Page 11
Commissioning.	Page 12
Station Number Programming.	Page 12
MODBUS Applications.	Page 12

2300-D16 Dimensions.

The 2300-D16 enclosure is shown below. The station clips directly onto an industry standard DIN rail. Field wiring is on the top of the station via a separate plug in connector. The station power and RS485 communications wiring are on a separate plug in connector on the side of the housing.

Allow at least 25mm on front and below the station to accommodate the wiring. Ensure that enough space is available above and below the station for good ventilation.

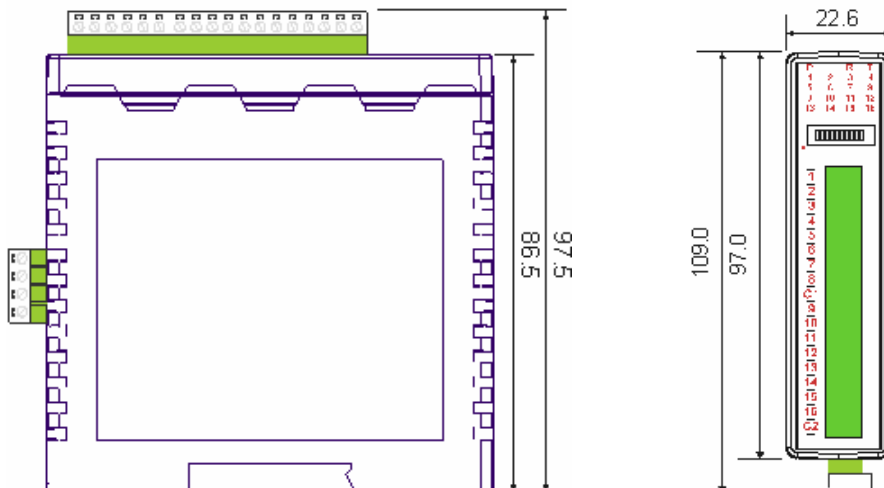

INTECH Micro 2300-D16

16 Channel, Isolated
Digital Inputs.

Features.

- 16 Digital, Isolated, Optocoupler Inputs.
- Modbus RTU, RS485.
- Selectable Baud Rates.
- Digital Inputs:
 - State or Count.
 - Speeds to 500Hz.
- Easy Programming Via MicroScan Maps.
- Plug-in Connectors Makes Replacement Easy.
- Programmable Station Number.
- Scaled Rate Value Via MicroScan Recorder.
- Scaled Totaliser Value Via MicroScan Recorder.
- Programming Information Retained on Power Down.
- 12~24Vdc Power Supply.
- Easy to Install.
- Compact DIN Rail Mount Enclosure.



2300 models include:

- 2300-A8I - 8 Current Inputs.
- 2300-A8II - 8 Isolated Current Inputs.
- 2300-A8VI - 8 Isolated Voltage Inputs.
- 2300-Tc8 - 8 Isolated Thermocouple Inputs.
- 2300-RTD6 - 6 RTD Inputs.
- 2300-MULTI - 2 RTD, 2 AI, 1 AO, 4 DI, 2 DO.
- 2300-D16 - 16 Digital Inputs.
- 2300-RO4 - 4 Relay Outputs.
- 2300-AO8I - 8 Current Outputs.
- 2300-NET - Isolated Ethernet TCP/IP to RS485.

Description.

The 2300-D16 remote station has 16 digital inputs. The inputs are isolated from the logic by bi-directional opto-couplers. The inputs are divided into 2 isolated groups of 8 inputs each. This allows for many configurations in which the input station may be used. One such configuration could be where one group is connected as common positive and the second group connected as common negative.

Ordering Information.

2300-D16 16 Digital Inputs. RS485 COMMS, Modbus RTU. 12~24Vdc Power Supply.

Factory Configurations.

The Intech Micro 2300 series I/O Remote Stations are factory configured to connect directly to MicroScan V5 software. Only the Station number (station ID) needs to be set via the easily accessible dip switches. No other station settings are required, making the new 2300 series one of the most friendly available. Simply setup the Station number on each 2300 station, install and the MicroScan software will scan the data hi-way and automatically locate each station. All stations will be displayed on a visual map.

I/O Expansion.

Expansion is made easy by simply installing another station with a unique station number and instructing MicroScan to find a new station. MicroScan will support up to 127 stations. Although RS485 data hi-way is rated for 1200 metres, it is recommended to use an RS485 booster every 500 metres or between each set of 16 stations. Due to the large variation in site conditions, this advice is based on typical site conditions and does not guarantee no fault operating conditions.



CAUTION: Dangerous voltages may be present. The 2300-D16 has no user serviceable parts. Protective enclosure only to be opened by qualified personnel. Remove ALL power sources before removing protective cover.



Quality Assurance Programme.

The modern technology and strict procedures of the ISO9001 Quality Assurance Programme applied during design, development, production and final inspection grant long term reliability of the instrument. This instrument has been designed and built to comply with EMC and Safety Standards requirements.

2300-D16 Specifications.

Digital Inputs:	16 individually isolated inputs with LED indication of each input	
-Input Voltage		12~24Vdc
-Load	@ 12 Vdc	5mA per Channel
	@ 24 Vdc	11mA per Channel
-Isolation		1500 Vrms between field and logic
-Resolution		32 bits
-Frequency		1KHz (max)
-Pulse Width		500us (min)

Note: Inputs 1 to 16 are used as both digital inputs and counter inputs.

Connectors:	-Power and Comms	4 Pin plug-in connector on side of station
	-Inputs	18 Way screw plug-in connector on top of station

Comms:	-Protocols	RS485, Modbus RTU
	-Baud Rate	9600
	-Format	8 bit, No Parity, 1 Stop

Power:	12~30Vdc
	30mA @ 12V / 17mA @ 24V

Safety and EMC Compliances:	
EMC Compliance	89/336/EEC and Low Voltage Equipment Directive 73/23/EEC
Safety Compliance	IEC 950

General Specifications: (Unless otherwise stated in other input specifications).		
Operating Temperature	-10~50°C	
Storage Temperature	-40~85°C	
Operating Humidity	Up to 95% non condensing	
Housing	-Dimensions	L=97.5, W=22.6, H=109mm
	-Mounting	35mm Symmetrical Mounting Rail.

Note 1. Contact INTECH INSTRUMENTS for more detailed programming information.

Product Liability. This information describes our products. It does not constitute guaranteed properties and is not intended to affirm the suitability of a product for a particular application. Due to ongoing research and development, designs, specifications, and documentation are subject to change without notification. Regrettably, omissions and exceptions cannot be completely ruled out. No liability will be accepted for errors, omissions or amendments to this specification. Technical data are always specified by their average values and are based on Standard Calibration Units at 25C, unless otherwise specified. Each product is subject to the 'Conditions of Sale'.

Warning: These products are not designed for use in, and should not be used for patient connected applications. In any critical installation an independent fail-safe back-up system must always be implemented.

Status Indicators.

Power:	Flashes to indicate the CPU is running.
RS485 Rx:	Flashes to indicate the unit has received a valid Modbus message.
RS485 Tx:	Flashes to indicate the unit has sent a Modbus message.
Input Status:	"OFF" when the input is off. "ON" when the input is on.

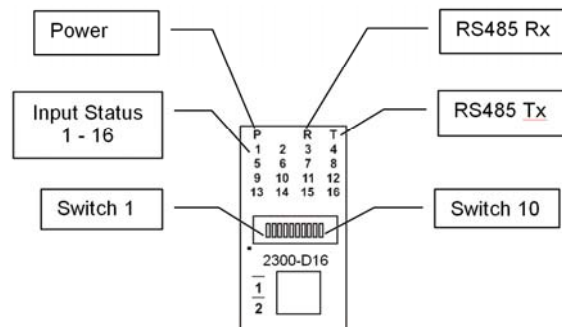

Station ID Table.

The following table assists with the setting up of DIP switches for the required Station ID (Station number).

STATION ID	DIP SWITCH SETTINGS						
	SW1	SW2	SW3	SW4	SW5	SW6	SW7
0	OFF	OFF	OFF	OFF	OFF	OFF	OFF
1	ON	OFF	OFF	OFF	OFF	OFF	OFF
2	OFF	ON	OFF	OFF	OFF	OFF	OFF
3	ON	ON	OFF	OFF	OFF	OFF	OFF
4	OFF	OFF	ON	OFF	OFF	OFF	OFF
5	ON	OFF	ON	OFF	OFF	OFF	OFF
6	OFF	ON	ON	OFF	OFF	OFF	OFF
7	ON	ON	ON	OFF	OFF	OFF	OFF
8	OFF	OFF	OFF	ON	OFF	OFF	OFF
9	ON	OFF	OFF	ON	OFF	OFF	OFF
10	OFF	ON	OFF	ON	OFF	OFF	OFF
11	ON	ON	OFF	ON	OFF	OFF	OFF
12	OFF	OFF	ON	ON	OFF	OFF	OFF
13	ON	OFF	ON	ON	OFF	OFF	OFF
14	OFF	ON	ON	ON	OFF	OFF	OFF
15	ON	ON	ON	ON	OFF	OFF	OFF
16	OFF	OFF	OFF	OFF	ON	OFF	OFF
17	ON	OFF	OFF	OFF	ON	OFF	OFF
18	OFF	ON	OFF	OFF	ON	OFF	OFF
19	ON	ON	OFF	OFF	ON	OFF	OFF
20	OFF	OFF	ON	OFF	ON	OFF	OFF
21	ON	OFF	ON	OFF	ON	OFF	OFF
22	OFF	ON	ON	OFF	ON	OFF	OFF
23	ON	ON	ON	OFF	ON	OFF	OFF
24	OFF	OFF	OFF	ON	ON	OFF	OFF
25	ON	OFF	OFF	ON	ON	OFF	OFF
26	OFF	ON	OFF	ON	ON	OFF	OFF
27	ON	ON	OFF	ON	ON	OFF	OFF
28	OFF	OFF	ON	ON	ON	OFF	OFF
29	ON	OFF	ON	ON	ON	OFF	OFF
30	OFF	ON	ON	ON	ON	OFF	OFF
31	ON	ON	ON	ON	ON	OFF	OFF
32	OFF	OFF	OFF	OFF	OFF	ON	OFF
33	ON	OFF	OFF	OFF	OFF	ON	OFF
34	OFF	ON	OFF	OFF	OFF	ON	OFF
35	ON	ON	OFF	OFF	OFF	ON	OFF
36	OFF	OFF	ON	OFF	OFF	ON	OFF
37	ON	OFF	ON	OFF	OFF	ON	OFF
38	OFF	ON	ON	OFF	OFF	ON	OFF
39	ON	ON	ON	OFF	OFF	ON	OFF
40	OFF	OFF	OFF	ON	OFF	ON	OFF
41	ON	OFF	OFF	ON	OFF	ON	OFF
42	OFF	ON	OFF	ON	OFF	ON	OFF
43	ON	ON	OFF	ON	OFF	ON	OFF
44	OFF	OFF	ON	ON	OFF	ON	OFF
45	ON	OFF	ON	ON	OFF	ON	OFF
46	OFF	ON	ON	ON	OFF	ON	OFF
47	ON	ON	ON	ON	OFF	ON	OFF
48	OFF	OFF	OFF	OFF	ON	ON	OFF
49	ON	OFF	OFF	OFF	ON	ON	OFF
50	OFF	ON	OFF	OFF	ON	ON	OFF

STATION ID	DIP SWITCH SETTINGS						
	SW1	SW2	SW3	SW4	SW5	SW6	SW7
51	ON	ON	OFF	OFF	ON	ON	OFF
52	OFF	OFF	ON	OFF	ON	ON	OFF
53	ON	OFF	ON	OFF	ON	ON	OFF
54	OFF	ON	ON	OFF	ON	ON	OFF
55	ON	ON	ON	OFF	ON	ON	OFF
56	OFF	OFF	OFF	ON	ON	ON	OFF
57	ON	OFF	OFF	ON	ON	ON	OFF
58	OFF	ON	OFF	ON	ON	ON	OFF
59	ON	ON	OFF	ON	ON	ON	OFF
60	OFF	OFF	ON	ON	ON	ON	OFF
61	ON	OFF	ON	ON	ON	ON	OFF
62	OFF	ON	ON	ON	ON	ON	OFF
63	ON	ON	ON	ON	ON	ON	OFF
64	OFF	OFF	OFF	OFF	OFF	OFF	ON
65	ON	OFF	OFF	OFF	OFF	OFF	ON
66	OFF	ON	OFF	OFF	OFF	OFF	ON
67	ON	ON	OFF	OFF	OFF	OFF	ON
68	OFF	OFF	ON	OFF	OFF	OFF	ON
69	ON	OFF	ON	OFF	OFF	OFF	ON
70	OFF	ON	ON	OFF	OFF	OFF	ON
71	ON	ON	ON	OFF	OFF	OFF	ON
72	OFF	OFF	OFF	ON	OFF	OFF	ON
73	ON	OFF	OFF	ON	OFF	OFF	ON
74	OFF	ON	OFF	ON	OFF	OFF	ON
75	ON	ON	OFF	ON	OFF	OFF	ON
76	OFF	OFF	ON	ON	OFF	OFF	ON
77	ON	OFF	ON	ON	OFF	OFF	ON
78	OFF	ON	ON	ON	OFF	OFF	ON
79	ON	ON	ON	ON	OFF	OFF	ON
80	OFF	OFF	OFF	OFF	ON	OFF	ON
81	ON	OFF	OFF	OFF	ON	OFF	ON
82	OFF	ON	OFF	OFF	ON	OFF	ON
83	ON	ON	OFF	OFF	ON	OFF	ON
84	OFF	OFF	ON	OFF	ON	OFF	ON
85	ON	OFF	ON	OFF	ON	OFF	ON
86	OFF	ON	ON	OFF	ON	OFF	ON
87	ON	ON	ON	OFF	ON	OFF	ON
88	OFF	OFF	OFF	ON	ON	OFF	ON
89	ON	OFF	OFF	ON	ON	OFF	ON
90	OFF	ON	OFF	ON	ON	OFF	ON
91	ON	ON	OFF	ON	ON	OFF	ON
92	OFF	OFF	ON	ON	ON	OFF	ON
93	ON	OFF	ON	ON	ON	OFF	ON
94	OFF	ON	ON	ON	ON	OFF	ON
95	ON	ON	ON	ON	ON	OFF	ON
96	OFF	OFF	OFF	OFF	OFF	ON	ON
97	ON	OFF	OFF	OFF	OFF	ON	ON
98	OFF	ON	OFF	OFF	OFF	ON	ON
99	ON	ON	OFF	OFF	OFF	ON	ON
100	OFF	OFF	ON	OFF	OFF	ON	ON

Table continued next page >>

STATION ID	DIP SWITCH SETTINGS						
	SW1	SW2	SW3	SW4	SW5	SW6	SW7
101	ON	OFF	ON	OFF	OFF	ON	ON
102	OFF	ON	ON	OFF	OFF	ON	ON
103	ON	ON	ON	OFF	OFF	ON	ON
104	OFF	OFF	OFF	ON	OFF	ON	ON
105	ON	OFF	OFF	ON	OFF	ON	ON
106	OFF	ON	OFF	ON	OFF	ON	ON
107	ON	ON	OFF	ON	OFF	ON	ON
108	OFF	OFF	ON	ON	OFF	ON	ON
109	ON	OFF	ON	ON	OFF	ON	ON
110	OFF	ON	ON	ON	OFF	ON	ON
111	ON	ON	ON	ON	OFF	ON	ON
112	OFF	OFF	OFF	OFF	ON	ON	ON
113	ON	OFF	OFF	OFF	ON	ON	ON
114	OFF	ON	OFF	OFF	ON	ON	ON
115	ON	ON	OFF	OFF	ON	ON	ON
116	OFF	OFF	ON	OFF	ON	ON	ON
117	ON	OFF	ON	OFF	ON	ON	ON
118	OFF	ON	ON	OFF	ON	ON	ON
119	ON	ON	ON	OFF	ON	ON	ON
120	OFF	OFF	OFF	ON	ON	ON	ON
121	ON	OFF	OFF	ON	ON	ON	ON
122	OFF	ON	OFF	ON	ON	ON	ON
123	ON	ON	OFF	ON	ON	ON	ON
124	OFF	OFF	ON	ON	ON	ON	ON
125	ON	OFF	ON	ON	ON	ON	ON
126	OFF	ON	ON	ON	ON	ON	ON
127	ON	ON	ON	ON	ON	ON	ON

Dip Switch Settings.

DIP SWITCH	FUNCTION	DESCRIPTION
1	STATION ID	+1 Station ID's from 0 to 127 are set up using switches 1 to 7
2	STATION ID	+2 "
3	STATION ID	+4 "
4	STATION ID	+8 "
5	STATION ID	+16 "
6	STATION ID	+32 "
7	STATION ID	+64 "
8	INVERT	When switched ON the status of the inputs is inverted
9	-	Not Used
10	BAUD RATE	For MicroScan use DIP Switch 10 ON (Factory default)

Power and RS485 Comms Wiring.

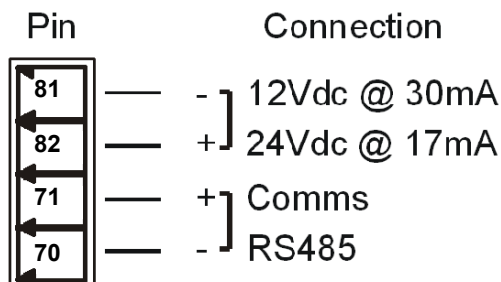

Warning: If the power/communication connections are reversed, the remote station may become faulty.

Connection Example Diagrams.

The following example diagram shows how the digital inputs are connected to potential free contacts: The common can be connected to positive or negative as indicated.

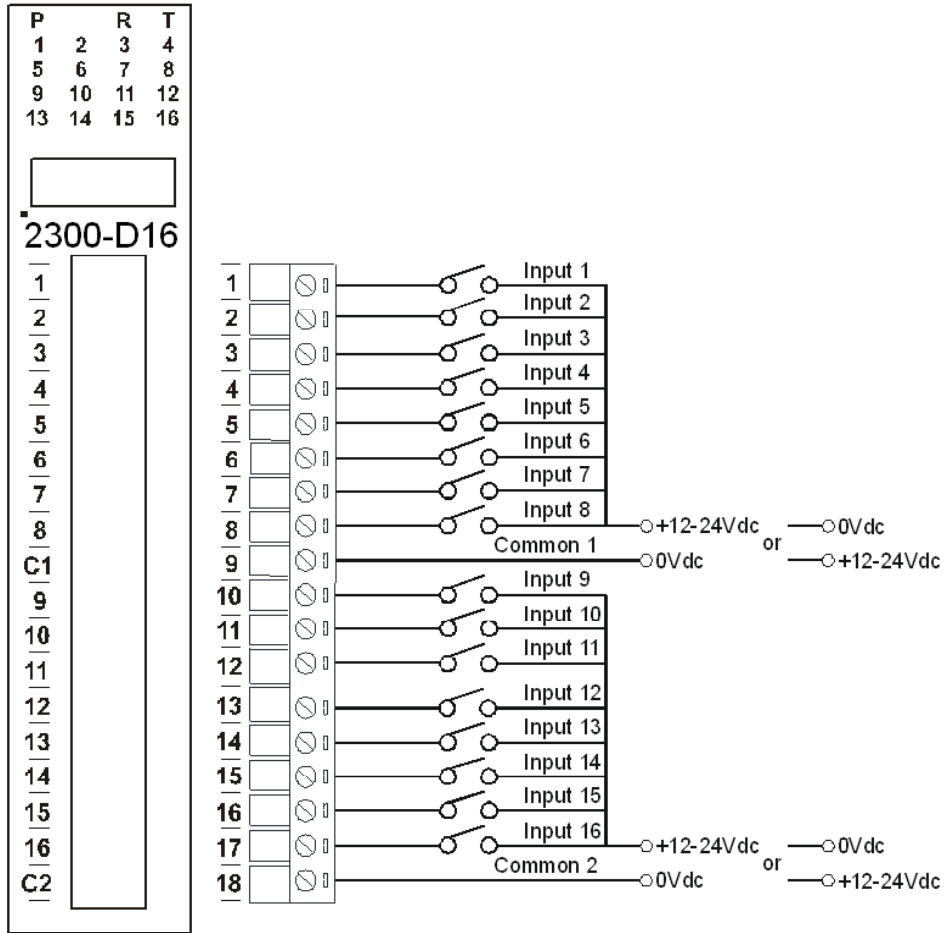

The following example diagram shows how the digital inputs are connected a NPN transistor or a PNP transistor:

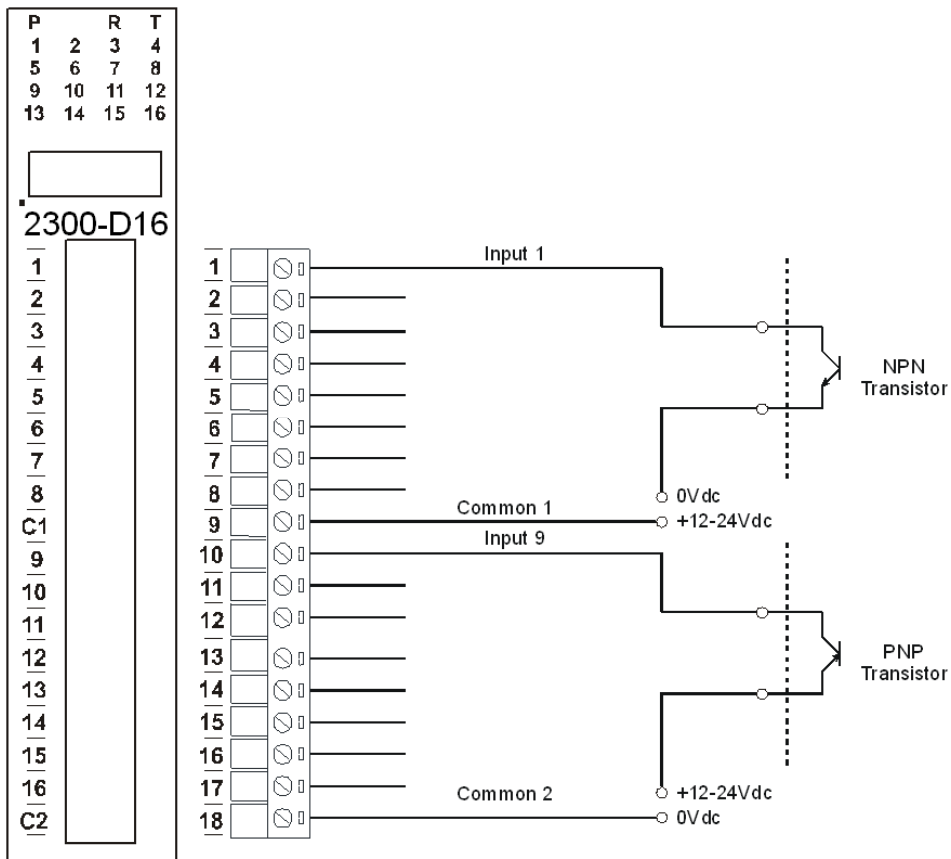

Computer to 2300 Series Comms Connections - 2400-IS:

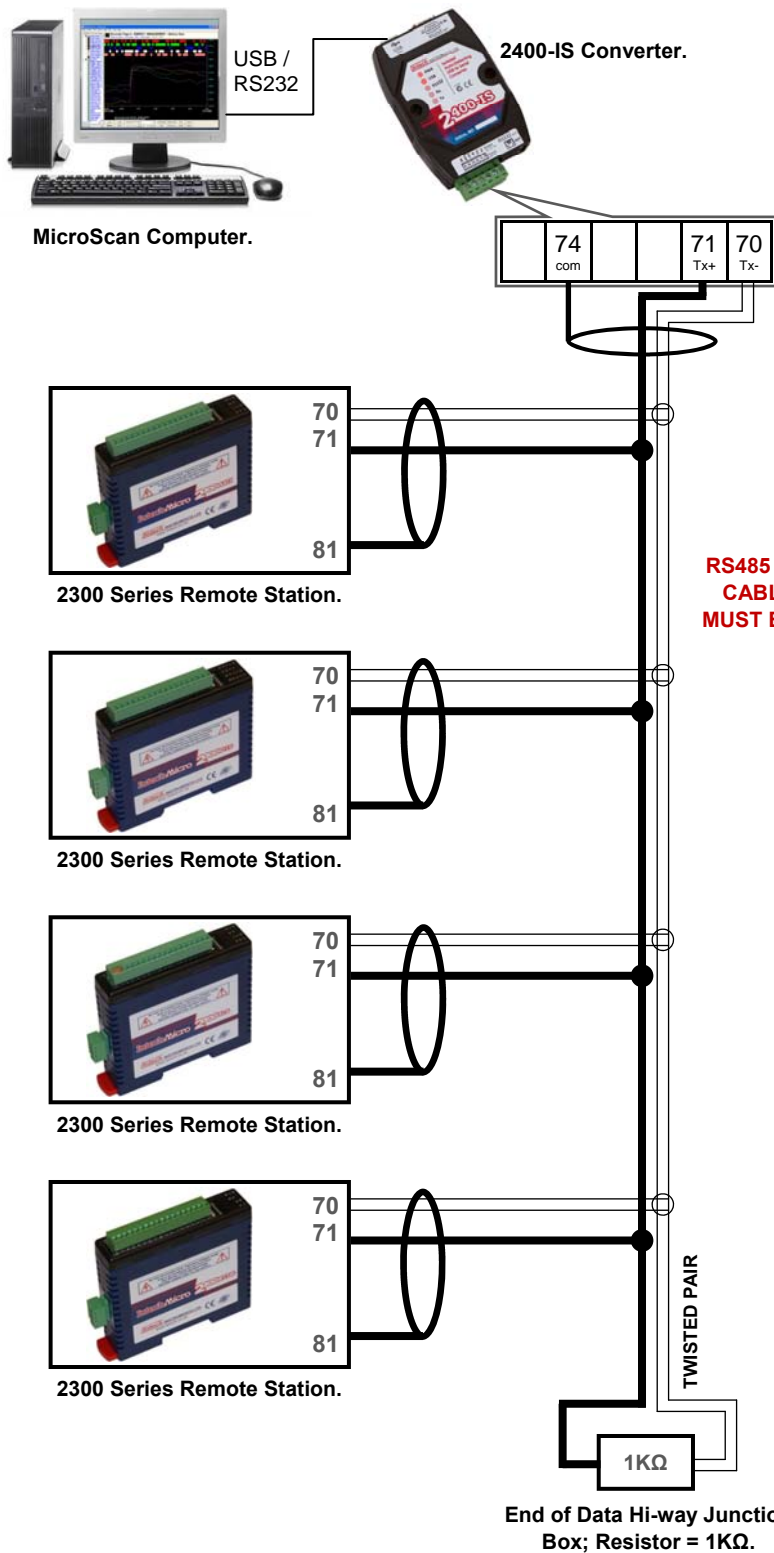

Never guess Tx or Rx connections.
Follow the terminal numbers in the serial connections diagrams exactly.

Important:

1. All cables must be screened.
2. All screens must be connected together.
3. The screen must not be earthed at any point.
4. **WARNING!** Take care to ensure that the screen does NOT contact terminal 82 on the 2300 station - damage will result.

Important: The 2300-XX stations **cannot** share a data hi-way with the 2400-XX / 2100-XX stations and/or Shimaden Controllers.

Computer to 2300 Series Comms Connections - 2100-IS:

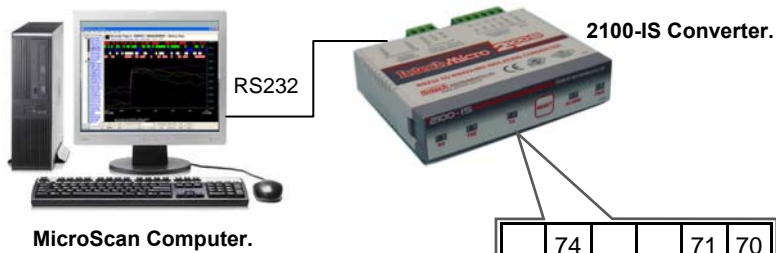

Never guess Tx or Rx connections.
Follow the terminal numbers in the serial connections diagrams exactly.

Important:

1. All cables must be screened.
2. All screens must be connected together.
3. The screen must not be earthed at any point.
4. **WARNING!** Take care to ensure that the screen does NOT contact terminal 82 on the 2300 station - damage will result.

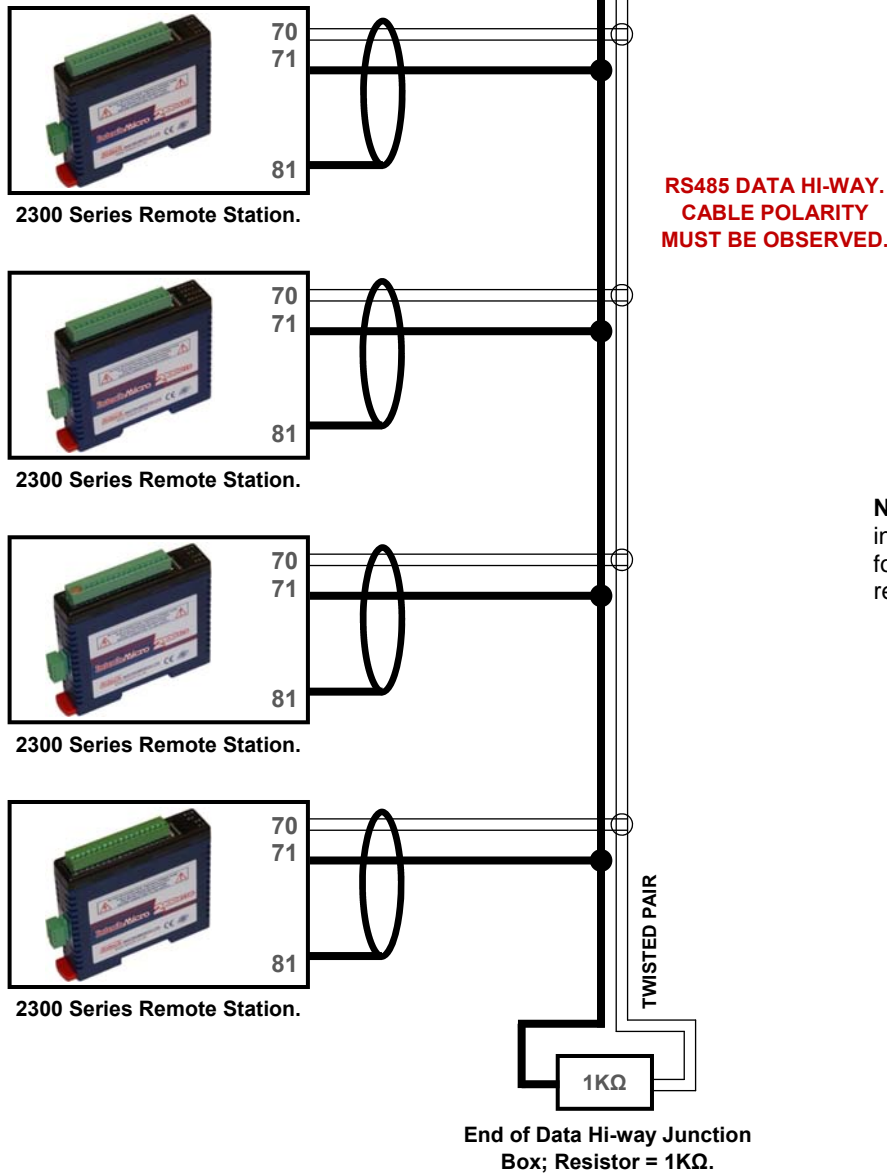

Note: The **2100-IS Converter** has an internal audible and relay output alarm for communication failure. For details refer to the 2100-IS Installation Guide.

Important: The 2300-XX stations **cannot** share a data hi-way with the 2400-XX / 2100-XX stations and/or Shimaden Controllers.

Computer to 2300 Series Comms Connections - 2300-NET:

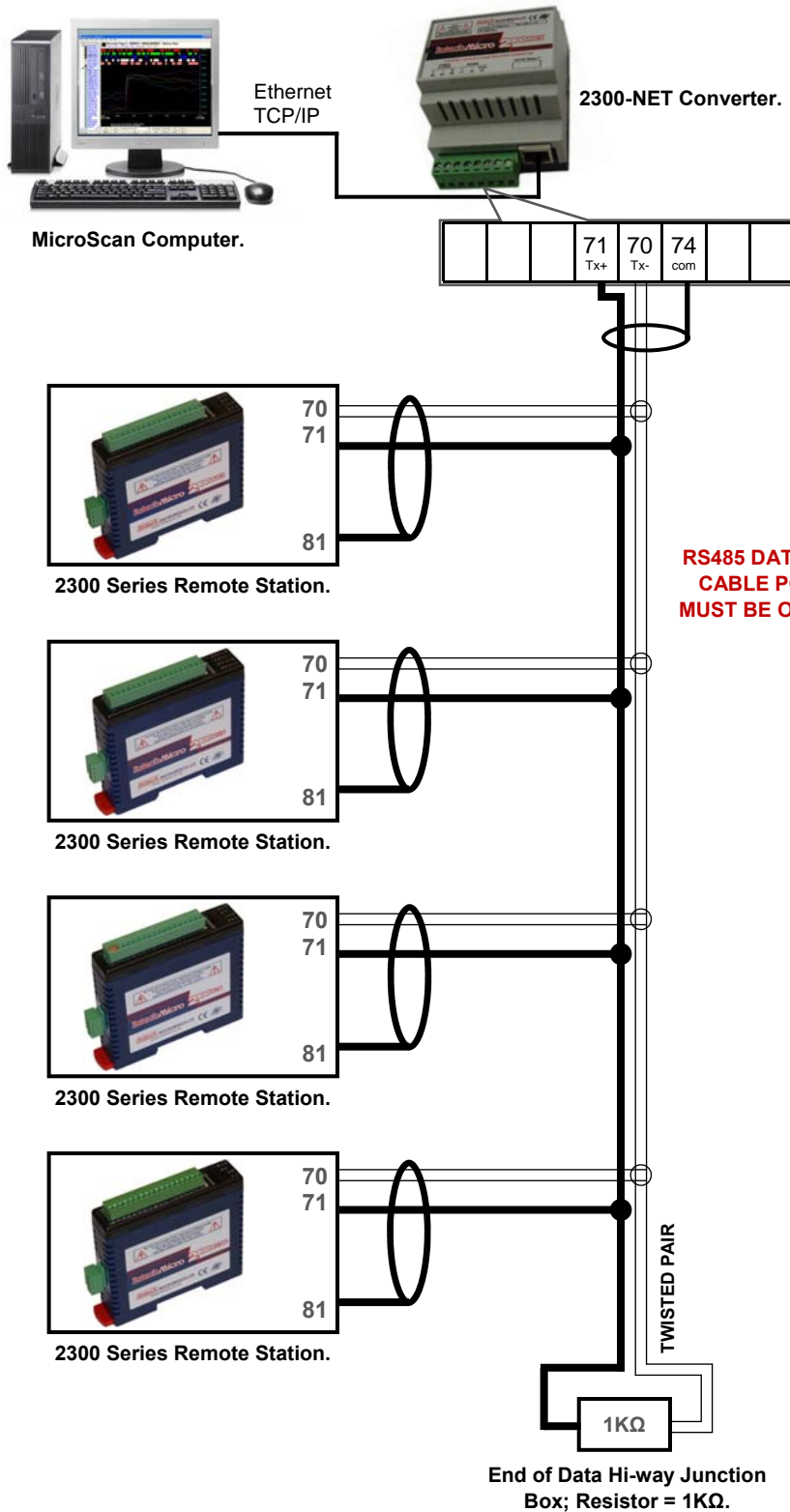

Never guess Tx or Rx connections. Follow the terminal numbers in the serial connections diagrams exactly.

Important:

1. All cables must be screened.
2. All screens must be connected together.
3. The screen must not be earthed at any point.
4. **WARNING!** Take care to ensure that the screen does NOT contact terminal 82 on the 2300 station - damage will result.

**RS485 DATA HI-WAY.
CABLE POLARITY
MUST BE OBSERVED.**

TWISTED PAIR

End of Data Hi-way Junction
Box; Resistor = 1KΩ.

Important: The 2300-XX stations **cannot** share a data hi-way with the 2400-XX / 2100-XX stations and/or Shimaden Controllers.

2300-D16 Wiring & Installation.

The 2300-D16 is to be Installed and Serviced by Service Personnel Only. No Operator / User Serviceable Parts.

All power and signals must be de-energised before connecting any wiring, or altering any Jumpers or Dip Switches. Do not start the MicroScan before programming in a unique station number. Refer 'Station Number Programming and Serial Number'.

Mounting.

* Also refer to Connection Diagrams and Notes.

- 1) Mount in a clean environment in an electrical cabinet on 35mm Symmetrical mounting rail.
- 2) Draft holes must have minimum free air space of 20mm. Foreign matter must not enter or block draft holes.
- 3) Do not subject to vibration or excess temperature or humidity variations.
- 4) Avoid mounting in cabinets with power control equipment.
- 5) To maintain compliance with the EMC Directives the 2300-D16 is to be mounted in a fully enclosed steel fire cabinet. The cabinet must be properly earthed, with appropriate input / output entry points and cabling.

Power Supply Wiring.

* Also refer to Connection Diagrams and Notes - 'Power and RS485 Comms Wiring' on page 14.27-6.

- 1) For power supply, connect Neutral (or -Ve) to terminal 81, Phase (or +Ve) to terminal 82.

RS485 Comms Signal Cabling.

- 1) Use only low capacitance, twisted pair, overall screened data cable. The cable must equal or better the following specifications:

Cable Specifications.		
Conductor Size.		7/0.20mm, 24AWG
Conductor Resistance @ 20C.		8.9Ω/100m
Max. Working Voltage.		300Vrms
Capacitance between wires of a pair.		50pF/m
Capacitance between each wire to all others bunched together.		95pF/m
Cross-talk between pairs:	@ 1kHz @ 100kHz	>-90dB/100m >-50dB/100m
Characteristic Impedance .	@ 100kHz	135Ω
Attenuation of a pair:	@ 1kHz @ 10kHz @ 100kHz @ 50kHz @ 1MHz @ 1.5MHz	0.15dB/100m 0.42dB/100m 0.8dB/100m 0.9dB/100m 1.9dB/100m 2.4dB/100m

NOTE: All cables are to be subject during manufacture to in-process spark testing @ 4kVrms.

All cables are to be tested between conductors and conductors to screen for 1min @ 1500Vrms.

- 2) Minimum cable pairs: RS485 = 1. (Plus overall screen.)
- 3) Take care not to stress or damage cables during installation.
- 4) Total length of trunk line, including spurs, is not to exceed 1200m without isolating boosters.
- 5) Terminating resistors = 1kΩ.
- 6) Cabling paths should avoid sources of radio frequency interferences such as fluorescent lights, variable speed motor drives, welding equipment, radio transmitters, etc.
- 7) There should be a minimum of 200mm physical separation between power cables and data cables.
- 8) Data cables should not be exposed to excessive heat or moisture, and should not be buried directly in the ground without protection.
- 9) Avoid powering a remote station or controller from the same power supply as a variable speed drive.
- 10) All unused twisted pairs should be terminated at both ends with 1kΩ resistors. DO NOT ground unused pairs.
- 11) **Important:** The 2300-XX stations **cannot** share a data hi-way with the 2400-XX / 2100-XX stations and/or Shimaden Controllers.

Analogue Signal Wiring.

- 1) All analogue cables should be good quality, overall screened, INSTRUMENTATION CABLE, with the screen earthed at one end only. (e.g. Austral Standard Cables B5102ES.)
- 2) Analogue signal cables should be laid a minimum distance of 300mm from power and data cables.
- 3) It is recommended that you do not earth analogue signal loops or use power supplies with ungrounded outputs.
- 4) Lightning arresters should be used on inputs and outputs when there is a danger from this source.
- 5) Refer to diagrams for connection details.

Commissioning.

- 1) Check that all the above conditions have been met, and the wiring checked, before applying power to the 2300-D16.
- 2) Check each relay output functions correctly, and the relay specifications are not being exceeded.
- 3) Check each digital input functions correctly, and the digital input specifications are not being exceeded.

2300-D16 Station Number Programming and Serial Number.

Important: When commissioning remote stations, you must programme a unique station number before using the programme setup button in the Scada Software. Requires MicroScan Version 5.0 onwards.

1. Close the MicroScan Scada down and turn the power off to the 2300 485 converter. Connect the new Remote Station, referring to '*Wiring and Installation*' and '*Commissioning*'
2. Turn power back on to the 2300 485 converter, and start MicroScan, under Setup Tools select Add New Station.
3. Select 'Page and Line Settings', or 'Tag Setup' and configure as per the MicroScan help file.

Important Note:

If using the 2400-IS converter, do not connect to the computer until after MicroScan has been installed.

MODBUS Applications:

If using the 2300-D16 station in other applications where **MODBUS** is required, please refer to the **2300-D16 MODBUS supplementary manual** which is available for download via the link from the Intech website: www.intech.co.nz/2300

Intech INSTRUMENTS LTD
www.intech.co.nz
Christchurch Ph: +64 3 343 0646
Auckland Ph: 09 827 1930
Email: sales@intech.co.nz
2300-D16 011113